

# Report

## ANOMALOUS MENTAL PHENOMENA RESEARCH IN RUSSIA AND THE FORMER SOVIET UNION: A FOLLOW UP

Larissa Vilenskaya & Edwin C. May, Ph.D.

### **ABSTRACT**

We describe our further exploration into research of anomalous mental phenomena (AMP) in the Former Soviet Union (FSU). We visited numerous research centers in major cities of Russia and the Ukraine, met with leading researchers in the field, visited their laboratories, and participated in some experiments. In their research, our Russian colleagues emphasize studies of anomalous perturbation (AP), also termed psychokinesis (PK), and "distant mental effect" on biological systems (bio-AP or bio-PK). The experiments have been conducted in top academic and research institutions, including Moscow State University, St. Petersburg State University, and several research institutes of the Russian and Ukrainian Academies of Sciences. Although the quality of research varies considerably in different institutions, there are groups that have developed rigorous methodologies. We also consider the potential cultural impact on Russian AMP research. We conclude with a discussion of the causal model of AP studies vs. informational, perceptual model in relation to the Russian research.

**KEYWORDS:** Anomalous, psychokinesis

## INTRODUCTION

Since the 1993 Convention of the Parapsychological Association, where we provided a narrative overview of research of anomalous mental phenomena (AMP) in the Former Soviet Union-FSU,<sup>1</sup> one of us (LV) undertook a return trip to the FSU, visiting Moscow, St. Petersburg and Kharkov and Simferopol in the Ukraine in November/ December of 1993. She met with AMP researchers in numerous academic and research institutions, including Moscow State University, St. Petersburg State University, and several research institutes of the Russian and Ukrainian Academies of Sciences. In addition, she participated in some experiments in these institutions. We present below the results of our analysis of our observations and impressions received in the course of these meetings, as well as an analysis of some data from the pertinent literature. We provide an evaluation of the methodological approaches of our Russian colleagues, whenever possible.

The main focus of Russian AMP research is studies in anomalous perturbation (AP), more commonly termed psychokinesis (PK). A diverse range of AP targets includes physical systems (*e.g.*, nuclear targets-spin-lattice relaxation, gas-filled stabilizer diodes, Schottky diodes, and quartz oscillators), bio-chemical systems (*e.g.*, pyrimidine derivatives), and biological systems (*e.g.*, microorganisms, plants, animals-morphology, biochemistry, physiology and behavior; humans-physiology and behavior). Many of these studies reported statistically significant results.

A broad scope of AP studies have been conducted in some of the most prestigious institutions throughout the FSU. Examples include Moscow State University (Biology and Psychology Departments), St. Petersburg State University (Biology Department), Simferopol State University (Division of Animal and Human Physiology) and research institutes of the Russian and Ukrainian Academies of Sciences and the Russian Academy of Medical Sciences.

The number of the institutes involved and the scope of their funding clearly indicate a keen interest of the Soviet (and later the Russian) government and academic circles in AMP research. According to one estimate, in the mid-1980s, there were approximately 40 institutes and laboratories with no less than 400 individuals nationwide, located from the Soviet Far East to the Ukraine, that

were involved in AMP research. Others in the FSU still quote larger numbers, from 700 to as many as 12,000 researchers and support staff. In particular, Dr. Firyaz Khantseverov, President of the Academy of Energo-Informational Sciences in Moscow, confirmed that no less than 700 individuals were involved in AMP studies in the USSR in 1987 and most continue now, either having full-time or part-time positions in research institutes or working independently with limited private funding. The fact that various official institutions conducted well-funded AMP research programs in the FSU has now been discussed extensively in both the Russian and the Western press.

Although government funding for AMP research in the FSU has been sharply reduced since 1991, a combination of government support, private support, and commercial ventures continue to enable Russians to pursue research projects. The quality of studies, however, varies significantly; Dr. Yuri Dolin's group<sup>2-4</sup> and the Division of Animal and Human Physiology of the Simferopol State University, associated with that group, appear to have the best methodologies and results that we have seen so far. In the remainder of this paper, we consider the Russian AP research topic by topic.

## **“DISTANT INFLUENCE” ON PHYSICAL SYSTEMS**

### INTRODUCTION

Russian AMP researchers claim more success in AP tests with-biological systems than with physical systems. At the same time, many prefer to work with physical systems which lack the variability inherent in living organisms. Below, we present examples of such studies.

### OPTICAL METHODS FOR THE STUDY OF AP PHENOMENA

Dulnev, Prokopenko, and Polyakova<sup>5</sup> of the Research Institute of Precise Mechanics and Optics in St. Petersburg described effects of gifted or trained individuals (they will be called “operators” henceforth) on various optical systems. The study was conducted in 1991-92.

In the first experimental series (15 trials with 5 operators), an operator's effect on the optical properties of water solutions of organic compounds was studied. This study was based on the fact that optical properties are sensitive to changes in the structure of a medium (e.g., parameters of symmetry of organic molecules, relationships between concentrations of the right and left components of the solutions, as well as exposure to electromagnetic, acoustical, and temperature fields). Because a high-precision optical polarimeter was used in the experiments, the error in measuring a change in the angle of rotation of the plane of polarization was less than 5 seconds of arc, with a temporal resolution of about 1 millisecond.

Figure 1 shows a schematic diagram of the device. Linearly polarized light of a He-Ne (helium-neon) laser (wavelength 0.63 micrometers) (1), was reflected from a mirror (2), was modulated by a disk modulator with the frequency of 2.5 kHz (3), was reflected by another mirror (4), and passed through polarizers (5, 6). The sequential position of the two polarizers acted as an attenuator and made it possible to modify the intensity of the polarized radiation which was incident on the solution (7). The laser beam was then directed to a Glan-Thompson prism (8) with its main plane of polarization at a small angle (about one minute of arc) with respect to the plane of polarization of the beam. In this way, the beam was divided into two beams, and respectively detected by photodetectors. The photodetectors were differentially connected to record the differential photoelectric current. The researchers proposed that AP rotated the liquid medium's plane of polarization and induced a change in the differential photoelectric current. The output signals were recorded by a strip-chart recorder; the analog signal may also be digitized for computer analysis.

Three out of five operators, at a distance from 70 cm to 2 meters from the device, "induced" from 10 seconds to 1 minute of arc rotation from 20-30% solution of glucose-D and up to 30 minutes of arc in 0.1 % solution of a second organic compound. This effect occurred, on the average, 1.5 minutes after the beginning of the operator's AP attempt. These results, including the polarization details, were replicated during tens of additional trials. No changes of this magnitude were observed in numerous baseline and control runs. Additional trials indicated that an increase in the concentration of the second organic solution by 10 yielded a two-fold increase in rotation of the plane of polarization produced by the operators.<sup>7</sup>

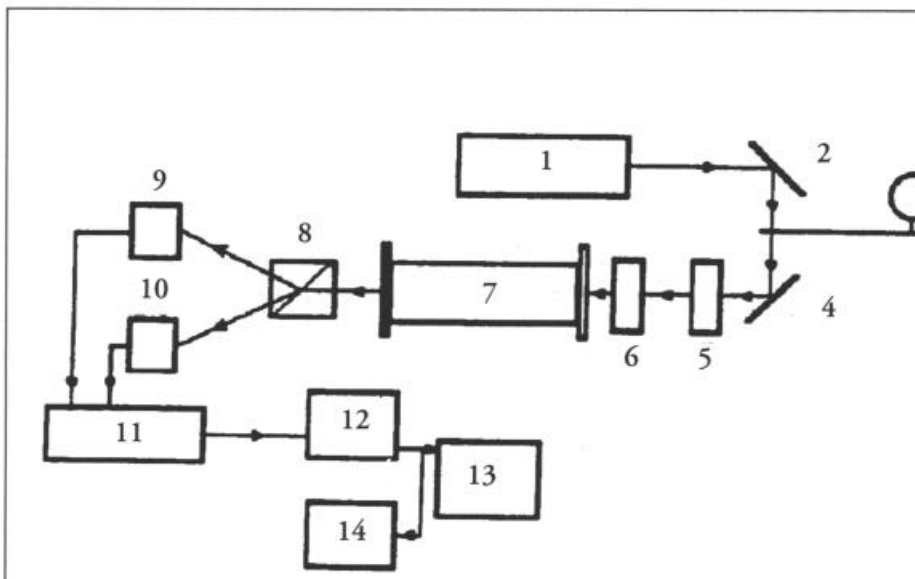

Figure 1. A diagram of the system for measuring optical activity of liquid media: (1) He- laser (wavelength 0.63 micrometers); (2,4) reflecting mirrors; (3) shutter; (5,6) polarizers; (7) cuvette with solution; (8) Glan-Thompson prism; (9,10) photodetectors; (11) comparison block; (12) amplifier; (13) oscilloscope; (14) strip-chart recorder.

Dulnev and his colleagues believe that the operator affected the solution and not the electronic equipment, because there were no changes in additional control runs with no solution present. Dulnev concludes that a change in the ratio of the right-rotating and left-rotating polarization components of the solution resulted from the operator's effort. On the basis of these experiments, optoelectronic sensors are promising devices to sense AP. Dulnev and his colleagues continue their search for optically active materials which have the highest sensitivity to operator influences. They suggest the practical idea of developing a methodology to protect electronic equipment from unpredictable effects related to the state of mind of the operators.

We believe the above conclusion is premature, because, as we learned from AP research at SRI,<sup>8</sup> the isolation of a physical system from known sources of perturbation and/or control of those sources is an expensive and time consuming task. Neither the published paper nor an unpublished report about

this study contain enough information for an independent methodological and statistical evaluation.

### **AP EFFECTS ON ANALYTICAL BALANCE**

In a published but incomplete report, Falkov and Keselman<sup>9</sup> from St. Petersburg described a series of AP trials on an analytical balance with a precision of +0.15 mg and careful controls of environmental factors, such as temperature, humidity, electromagnetic fields, etc. Two identical balances were placed in the same room. One was the test balance and another acted as a control. The study was conducted with one selected operator. In hundreds of trials when the operator was from 1 to 3 meters from the balance, Falkov and Keselman observed a 1 to 3 mg increase of the target balance in over 50% of the trials and less than 0.1 mg change in the control balance. This effect is 1 to 1.5 orders of magnitude greater than seen in the control. With this magnitude of change, no statistical evaluation is necessary. We do, however, possess only a single published report on this study and did not witness the actual experiment. To fully understand the experiment, we feel that the methodology should be carefully reviewed in person or in a joint replication effort.

### **EFFECT ON THE ACIDITY OF WATER**

Biologists Andrei B. Rubin, Tatyana Ye. Krendeleva, Sergei I. Pogosyan, and Valery B. Turovetsky<sup>10</sup> at the Division of Biophysics, Department of Biology, Moscow State University, conducted several pilot studies on AP effects on animate and inanimate systems. We revisited this laboratory in late 1993 and discussed in detail their experimental methodologies and results. In one study, Igor B. Verbitsky, a sensitive and healer, was asked to affect the acidity (pH) of water or water solutions. He worked for three to five minutes at a distance of from 20 to 30 cm from the flask. The target solution was placed in a water thermostat. The effects were observed under all studied temperatures from 5 to 48°C. These changes were observed only when the target solution was continuously stirred by a magnetic or mechanical mixer. Verbitsky claimed that his work on affecting pH was a learning process: at the beginning, he could produce only relatively small changes in pH, and now he is able to change the acidity

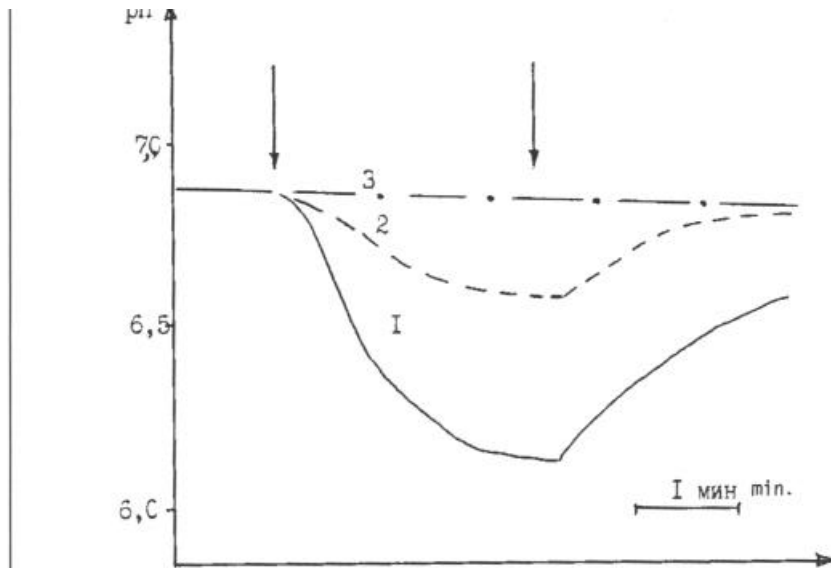

*Figure 2. Typical changes of pH during the operator's effect (the arrows show the beginning and end of the operator's effort period): 1-distilled water; 2-salt solution; 3-non-stirred solution.*

by 1.5 units of pH. In alkaline solutions (pH = 8.0 - 9.0), the effect is usually irreversible; in acidic solutions (pH = 5.0 - 6.0), the pH gradually returns to the initial level after the operator's influence (see Figure 2) is removed.

The researchers believe that these pH changes are due to changes in the solubility of carbon dioxide in the water. This conclusion does not seem plausible because there is such a small concentration of carbon dioxide in air. When we first visited this laboratory in the Spring of 1993, we saw an obvious artifact in the test: the flask was not covered, and the operator's breathing could increase the acidity, especially because he is a heavy smoker.

During our return visit to this laboratory, we found that the researchers have conducted tests in totally closed flasks and with the operator (Verbitsky) sitting at a distance from 0.5 to 3 meters from the flask. Positive results were observed as long as some air remained in the flask above the target solution.

## **SYSTEMS WITH MULTIPLE PHYSICAL SENSORS**

Dr. Yuri S. Dolin and his associates developed several sophisticated systems for AP experiments. In most of these, they were primarily interested in long distance effects (i.e., hundreds meters to several kilometers from the target). Since Dolin's group is known for their methodological thoroughness, we tend to place more emphasis on their experimental work.

An unpublished research report prepared by this group provides detailed descriptions and circuit diagrams of 13 types of devices for the study of AP on physical systems. The sensors used in these devices include gas-filled stabilizer diodes, field and bipolar transistors, Schottky diodes, tunnel diodes, photo-multiplier tubes, quartz oscillators, and liquid crystals. The output parameters of these sensors are voltage, frequency, etc. Their report also describes an arrangement of up to 15 different devices in the form of an array. They often use a computer to provide a majority vote of the input to detect an AP effect. Unfortunately, the material we have does not contain sufficient data for statistical evaluation of their results.

## **“DISTANT INFLUENCE” ON BIOLOGICAL SYSTEMS**

### **INTRODUCTION**

There have been a number of methodologically sound studies of AMP effects on physiology, biochemistry, and behavior of animals and humans. These studies, for the most part, were conducted at the most prestigious research institutes of the FSU. One of the interesting features of Russian AP studies with biosystems is that researchers, who are familiar with standard methodologies, employ these same methodologies to elucidate human operators effects on these same systems. From a positive perspective, this means that the behavior of these systems and their baseline parameters are well understood. Unfortunately, some of the researchers are not as familiar with methodologies of AMP research. However, some of the groups with which we do interact on a regular basis, are knowledgeable of both methodologies. For example, a rigorous research program to study human operator's distant effect on plant, animal, and human physiology is being conducted by Dr. Yuri S. Dolin and his associates in Moscow.<sup>3,4,11</sup>

## **EXPERIMENTS WITH TISSUE CULTURES**

The Research Institute of Especially Pure Biological Compounds in St. Petersburg conducted AP studies with tissue cultures. The project was headed by Yuri V Tyagotin, a biologist. Operator Yevgeny G. Bondarenko<sup>12</sup>-there were 3 other operators as well, including Tyagotin himself-was at a distance of about 2 meters from an arrangement of 24 (96 in some tests) cylindrical openings, each containing cells from the same tissue culture. They were arranged in several rows, and one row was chosen randomly as a target (*i.e.*, to affect the cell growth only in this particular row, without affecting cells in adjacent rows 2 cm away). Tyagotin observed intended AP effects, but from their description it was not clear whether the experiment was conducted under double-blind conditions.

In another study, Tyagotin and Bondarenko<sup>13</sup> showed that when hybrid cells, which contained a double set of chromosomes from two of their predecessors (*i.e.*, normal cells of a mouse's spleen and a tumor line of mouse cells), were used as targets, an inhibition of growth of cellular clones of the hybrids with dominating activity of the genes of tumor origin was observed. Russian researchers<sup>14</sup> interpret the above results as indicating that individuals who possess AP abilities are able to cause irreversible changes at an animal cellular division level. We believe, however, that this conclusion may be premature. There were insufficient details in the material to justify their claim of definitive AP-effects on biological systems.

A group of researchers at the Institute of Precise Mechanics and Optics in St. Petersburg used various biological systems as AP targets. The studies were conducted in conjunction with St. Petersburg State University (Biology Department) and Agrophysical Institute. While in St. Petersburg, one of us (IV) met with recently retired Dr. Nikolai V Verzilin, a former professor at the Division of Plant Physiology and Biochemistry of St. Petersburg State University. Until early 1993, this group conducted several AP experiments, including one with unicellular algae as a target. In their tests, an operator attempted to affect the cytoplasm movement in a cell. An effect was produced at a distance of several meters from another room under good methodological conditions. Some tests were conducted from a distance of tens of kilometers. Because in pilot trials the data were slow to return to baseline, no more than

one trial per day (test or control) was performed. The results were statistically significant ( $p < 0.01$ ). Another method used by this group involved a study of oxidation and reduction processes in plants, that is the recording of the intensity of fluorescence of reduced pyridinenucleotides.<sup>15</sup> Sadly, we do not yet have further information on this experiment or the next experiment.

Similarly, the above-mentioned group at the Biophysics Division of Moscow State University<sup>10</sup> employed known biophysical methods in bio-PK tests. In particular, they used intracellular pH of mouse peritoneal phagocytes as an AP target and obtained statistically significant results in a pilot study with a selected operator.

### **NEW EXPERIMENTS ON DISTANT EFFECT ON MICE**

Dr. Sergei Speransky of the Institute of Hygiene in Novosibirsk, whose AP studies were discussed in our previous paper,<sup>1</sup> conducted a new study of an operator's effect on mice's physiology in November 1993. As a toxicologist, Speransky<sup>16</sup> applies standard procedures to AP studies. There were 12 white mice in the test group and 12 in the control group, and Speransky and his assistant Kukharenko were blind to which group was the test group. The randomization (a coin toss) was done by a known healer, Lesya Gorbovets, just prior to the trial. During an one-hour period of time, the beginning of which was determined by Speransky, Gorbovets attempted to affect from Moscow the randomly selected group of mice in Novosibirsk. Before the AP attempt, the mice of both test and control groups were poisoned by carbon tetrochloride (the same dose for both groups). Thus, Gorbovets's task was to affect positively (i.e., to heal) the mice in the test group while leaving the control group untouched.

Two days later seven mice (58.3%) in one group died, without a single mouse's death in the other group. When the condition was disclosed, it turned out that the group in which all mice survived was the test group subjected to the AP influence. It is worthy of note that Gorbovets was the second operator who turned out to be successful in Speransky's experiments.

An unrelated study conducted at the Oncology Research Center of the Russian Academy of Medical Sciences in 1991 also used mice's physiology as an AP

target.<sup>17</sup> The mice were first implanted with malignant tumors and then divided randomly into experimental and control groups. Healers attempted to affect 5 or 10 mice at a time in a cage, while in the same room at a distance of about 1 meter. The intention of the healer was to suppress the tumor growth. Neither the researchers nor support personnel who handled the mice during this experiment knew which symbols on the cages denoted experimental or control animals. The researchers measured and recorded several parameters, including the rate of tumor growth and the lifespan of the animals. As an unexpected outcome, in a series with 30 test and 37 control animals, the lifespan of the test mice was 20% lower than control ( $p < 0.01$ ). With respect to the tumor growth, however, the outcome turned out to be mixed (*i.e.*, some appeared to respond to the healer while others did not). Because the reporting style in Russia is often different from Western standards, it is difficult to evaluate from an unpublished report whether changes of other recorded parameters are significant.

## **AP ON BEHAVIOR OF LABORATORY ANIMALS**

Researchers at the Division of Animal and Human Physiology of the Simferopol State University, headed by Dr. Nataliya P Yanova<sup>18</sup> use animal behavior as an AP target. The behaviors included modes of social interaction of the animals, the “open field” method (which makes it possible to record up to 28 behavioral parameters), and conditioned responses. They report good reproducibility of results in well-controlled conditions.

Their recent experiments included a study of social interactions in a group of rats. They designed a model which emphasizes the social roles (*i.e.*, dominant/subdominant relationships) of the animals in a group. This model involved social isolation of one of the animals. Under ordinary conditions, in each animal group (6 animals), one dominant and 2 or 3 subdominant individuals were found, the rest of the animals were passive. The cage then was divided into 3 parts, with one animal being placed in the central part (*i.e.*, in social isolation), and 2 or 3 animals in each of the other parts. Each animal was given a chance to spend time in social isolation. Then, when the doors between the partitions were lifted, the formerly isolated animal fought back for its territory. This way, dominant animals remained dominant and subdominant animals

remained subdominant; their roles were clearly emphasized after social isolation. This was the control condition.

There were three test conditions: (1) effect of magnetic fields-EMF (8 Hz, 5 millitesla) for 3 hours; (2) operator's effect for 30 min., in a shielded facility, at a distance of about 3.5 to 4 meters from the cage with the animals; and (3) EMF plus the operator. The operator was directed to produce a stimulating effect, with positive emotions (the possible options were up/down, positive/ negative emotions).

With EMF alone, in a significant number of instances ( $p < 0.05$ ), subdominant animals became dominant, and aggressiveness of all of the animals (*e.g.*, the number of attacks) increased. With operators, the differences between the dominant and subdominant animals (*i.e.*, the hierarchical structure of this social group) virtually disappeared. With the combined effect of the EMF plus operator, the animals' behavior was close to the situation of the operator alone (*i.e.*, there were no significant differences in the elements of social interaction between the animals and no clear division into dominant/subdominant roles of the animals).

Preparation of a publication on this study is underway and a replication is being scheduled; however, the group currently experiences financial difficulties due to the poor economic situation in the FSU.

### **BIOCHEMICAL CHANGES IN LABORATORY ANIMALS AS AP TARGETS**

A number of researchers in the FSU have conducted systematic studies of AP on brain systems which are responsible for regulating the secretion of major neuromediators. These include acetylcholine, noradrenaline, dopamine, and serotonin-neurotransmitters that underlie and regulate behavior in animals and humans alike.

Earlier, similar experiments were conducted at the Leningrad Mining Institute in the mid-1980s (at that time, the laboratory director was physiologist Gertruda N. Vasilyeva, who is currently with the Research Institute of Fine Mechanics and Optics in St. Petersburg). They involved the study of AP on

enzyme balance in vitro and in a living system. The chosen enzyme was acetylcholinesterase, an enzyme found in blood and various tissues that catalyze hydrolysis of acetylcholine; the latter is the chemical mediator of cholinergic nerve impulses. In informal discussions, our Russian colleagues referred to numerous trials in controlled conditions with positive results from selected operators, but the results have not been published.

In the early 1990s, a biochemistry study was conducted by the above group at Simferopol State University, under the conditions outlined on pages 241 and 242. With the EMF, the biochemistry was consistent with behavior of the animals. There were increased levels of noradrenaline and dopamine significant differences as compared to control animals (this might explain an increased aggressiveness of the animals). With operators, the noradrenaline level in former dominant animals was still relatively high (although not as high as with the EMF), as it should be in dominant animals, but they stopped being dominant: as pointed out above, the hierarchical structure was not pronounced. In other words, a statistically significant behavioral effect was observed but not a biochemical effect. Motor activity of these animals who had been subjected to the AP operator was also not consistent with a higher level of noradrenaline- (*i.e.*, there was no increased motor activity, all of the animals in the social group were at approximately the same level, without individual differences). With combined EMF and operator, the content of noradrenaline and dopamine were at the same levels as with EMF effect alone, but no statistically significant change of social roles was observed. An assumption of the researchers was that an operator acted similarly to the cerebral cortex in humans (*i.e.*, if an individual has a high level of noradrenaline, as a rule, he/she does not become openly aggressive); here the operator purportedly acted as a means for controlling/regulating the animals' behavior.

## **MORPHOLOGICAL CHANGES IN ANIMALS AS AP TARGETS**

The third study conducted at the Simferopol State University involved morphological (electron-microscopic) examination of structural changes in specific areas of the brains of experimental animals under the conditions described on pages 241-242. This study was conducted jointly by the Division of Human and Animal Physiology of the Simferopol State University and the Research Institute

of Experimental Medicine of the Academy of Medical Sciences in St. Petersburg in 1992-1993. The first study and two subsequent replications produced consistent results.<sup>19</sup> The brain structures chosen for the morphological examination (*i.e.*, the substantia nigra, the locus coeruleus, and the raphe nuclei) were chosen because they represent the structures responsible for the regulation of secretions of major neurotransmitters, namely noradrenaline (the locus coeruleus), dopamine (the substantia nigra), and serotonin (the raphe nuclei).

Morphological examination involves qualitative and not quantitative descriptions of the studied cellular structures. However, the technique is routinely used for biological and medical purposes (*e.g.*, to distinguish between benign and malignant tumors). The morphologists, who were blind to the conditions, were asked to evaluate the samples. They were even not aware of the nature of the experiment.

The most pronounced cellular changes in the structures of the brain were observed in cases of EMF exposure, as compared to the control. In the group of rats, that were subjected to AP, the changes were apparent but less pronounced. With the combined effect, field plus operator, the degree of ultrastructural changes in neurons was less pronounced than with the action of the field alone. In the second and third replication of the study, the outcome was similar: EMF produced the largest effect, operator produced the least (although noticeable) effect, and with the combination of “field plus operator” there was a mitigating, softening effect, as compared to the “field” alone (*i.e.*, an operator was thought to exert a controlling, regulating effect).

## **HUMAN PHYSIOLOGY AS AP TARGETS**

Dr. Yuri S. Dolin's studies of AP effect on a target individual's EEG were successfully replicated at the Simferopol State University.<sup>18</sup> In these studies, remote agents were asked to influence sensorially isolated subject. The effects were observed as changes in brainwave power spectra. Overall, over 800 trials were conducted. Of them, 249 trials were conducted during 1993, with 56 test and 90 control trials with two operators in Moscow and two receivers in Simferopol (a distance of over 1,000 km). Thirty-seven test and 66 control trials were conducted with one operator and two receivers in Simferopol (a

distances of 5-10 km). In total, three operators and two receivers participated. EEGs of the receivers were recorded and the standard brainwave frequencies were analyzed.

A decrease in the power of delta and theta rhythms was found in test trials, as compared to control trials ( $p < 0.05$ ). In addition, the receivers (who were blind as to the given trial being either test or control) were asked to rate on a 10-point scale their subjective assessment of the intensity of their impressions and sensations during each trial. Mean ratings during test and control trials were then compared, and the difference was found to be significant. While the changes in the brainwave power did not show any decrease with distance, subjective ratings of the receivers did show a decrease of the effect with distance: the tests within Simferopol yielded  $p < 0.007$  and between Moscow and Simferopol  $p < 0.03$ .

Correlation with the intensity of the variation of geomagnetic fields was found to be significant for separate operator-receiver pairs but not consistent from one pair to another. While some operator-receiver pairs performed better during geomagnetically quieter days, others showed significant changes in brainwave power in the test trials conducted during days of increased geomagnetic activity. The researchers plan to continue these investigations.

In these and other experiments, much attention was placed on the study of selectivity of the effect. That is, significant differential effects were observed when two isolated AP targets were at a distance of one or several meters from each other and the operator was asked to affect the physiology of only one of them.

The same group conducted about 200 trials with humans in which evoked potentials were recorded (i.e., expectancy wave and readiness potential computed from the EEG when a receiver was given a specific task to perform while his EEG was monitored). There was a statistically significant difference between the AP and control condition ( $p < 0.01$ ).

#### HUMAN PERFORMANCE AS AP TARGETS

An unpublished study of a series of AP on human performance trials was conducted jointly by researchers of the Moscow State University Psychology

Department and the Institute of Psychology of the Russian Academy of Sciences in Moscow.<sup>20</sup> There were five AP operators and nine subjects. Each subject was given the task of detecting a weak auditory signal presented within white noise. Trials containing the white noise plus signal and the white noise alone were presented in random order, for a total of 120 trials for each subject. There were three possible conditions: (1) control; (2) “open” AP, where the operator was in the same shielded chamber as the subject, at a distance of about 2 meters; and (3) “covert” AP, where the operator was located outside the shielded chamber. The subject was kept blind to differences between the control and the “covert” AP condition. (It should be noted that the researchers were aware of the fact that the “open” condition did not test for AP-but they were still interested in exploring this condition's possible relevance to the phenomenon of "mental" healing, currently wide-spread in Russia.) There were also two kinds of effect trials. The operator had either to enhance or to inhibit the subject's performance in detecting the weak auditory signal. For each trial of the test series, several parameters of the subject's performance were calculated, including the number of hits, the number of false alarms, the reaction time, and the variance of the reaction time.

The analysis showed that the desired direction of the effect was not achieved (i.e., there was no statistically significant difference in any of the parameters between the control and the performance-enhancing or performance-inhibiting condition). As expected, there was a statistically significant difference in the reaction time between the control and the “open” test condition. There was also a difference between control and “covert” conditions, if the direction of the effect (up or down) was disregarded ( $p = 0.03$ ). There were considerable differences between outcomes of operator-subject pairs, with one pair demonstrating the largest decrease in the subject's reaction time ( $p < 0.001$ ) during the “covert” (presumed AP) condition.

This study, however, has an essential drawback in that there was no proper randomization of the conditions, with the control condition always being first. When asked about it, the authors answered that they did not see a problem since each subject participated in the sequence of trials only once. However, it remains a drawback because they seem to disregard the possibility of learning and/or fatigue.

## DISCUSSION AND CONCLUSIONS

Since the reporting standards often differ in many non-Western countries, many problems are encountered. Additionally, as far as Russia is concerned, much of the information at our disposal consists not of scientific papers published in refereed journals but of unpublished internal research reports. Depending upon the amount of information at our disposal, we provide an evaluation of the methodological approaches. In some instances, we present an analysis of experimental methodologies even when the results are not available or presented in a way which does not allow a comprehensive evaluation.

Two medical doctors, formerly from the FSU, now living in California, described the Soviet situation in the 1970's and 1980's as follows:

The persecution of spiritual schools [in Russia] may seem to contradict the well-known fact that the Soviets conducted official research in paranormal phenomena and extrasensory perception. However, if we look closer, this only confirms the truth spoken of by many spiritual masters: siddhis ["paranormal" powers] are not the proof of proximity to God or enlightenment and should be disregarded by the serious seeker. Indeed paranormal abilities without ethics and a commitment to spiritual growth may be turned to evil. Hence the KGB could sponsor research on ESP while at the same time persecuting people with higher goals.<sup>2</sup>

Kungurtsev and Luchakova do not question the existence of AMP but rather question the ethics of those who conducted this research. Acceptance of AMP stems from the Russian folk tradition and culture, and most researchers have little doubt in the existence of AMP. On the positive side, this may reduce the possibility of negative experimenter effects; sadly, it may lead to a laxity of research methodology. In addition, as with some of our Western colleagues, Kungurtsev and Luchakova presume a link between AMP and spirituality. In our opinion this conclusion does not seem to be warranted on the basis of what is known today about AMP—at least it is not more justified for AMP than for other known sensory systems.

It is very clear from our investigations that there has been, and continues to be, substantial research interest in AMP in the FSU. As would be expected with such a large effort, some groups and studies are better than others. Because

insufficient data were available to perform quantitative assessment of most of this research, we have provided narrative descriptions based on the material in hand.

Although our colleagues in the FSU made significant effort in bio-AP studies, this approach is not unique to Russia. Their results are comparable to those of the best Western AP research with biological systems.<sup>21</sup> An example is remote observation experiments (AP effect monitored by changes of subjects' electro-activity) which have been successfully replicated several times, including a replication in our laboratory.<sup>22</sup>

While it is clear that the Russian point of view favors anomalous perturbation as an underlying mechanism, the question is far from settled in the West, where a perceptual (selection) model has been also considered.<sup>23,24</sup> Because an AP model implies a possibility of both positive and negative effects on biological systems, Tart<sup>15</sup> and many others are concerned about the potential negative uses of AMP. These concerns will be ameliorated if the mechanism turns out to be correlational as opposed to causal. To settle this question of mechanism, significant independent and cooperative replication is required.

Clearly, the best studies from this collection should be independently repeated. In addition, we urge that joint ventures be established between research groups in the West and in the FSU, such that we all may benefit from the substantial expertise of both countries.

CORRESPONDENCE: Edwin C. May, Ph.D, • Cognitive Sciences Laboratory  
• Science Applications International Corporation (SAIC) • Menlo Park, CA  
94301

ACKNOWLEDGEMENTS We are grateful to all our friends and colleagues in the Former Soviet Union who generously shared with us their knowledge. Without their kind and open assistance, this paper would never be possible. We would also like to express our thanks to Christine James for her editorial comments.

## REFERENCES AND NOTES

1. E. C. May & L. Vilenskaya, Some Aspects of Parapsychological Research in the Former Soviet Union, *Proceedings of the 36th Annual Convention of the Parapsychological Association* (Toronto, Canada, August, 1993), pp. 57-74.

2. I. Kungurtsev & O. Luchakova, The Unknown Russian Mysticism, *Gnosis* (Spring, 1994), pp 21-27.
3. Yu. S. Dolin, V. A. Davydov, E. V. Morozova & D. Ye Shumov, Studies of a Remote Mental Effect on Plants with Electrophysiological Recording, *Proceedings of the 36th Annual Convention of the Parapsychological Association* (Toronto, Canada, August, 1993), pp. 41-56.
4. Y. S. Dolin, V. I. Dymov & N. N. Khatchenkov, Preliminary Study of a Human Operator's Remote Effect on the Psychophysiological State of Another Individual with EEG Recording, *Proceedings of the 36th Annual Convention of the Parapsychological Association* (Toronto, Canada, August, 1993), pp. 24-40.
5. G. N. Dulnev, V. T. Prokopenko & O. S. Polyakova, Optical Methods for the Study of Psi Phenomena, *Parapsikhologiya i Psikhofizika* [Parapsychology and Psychophysics], 1, 9 (in Russian, 1993), pp. 39-44.
6. At this writing we are uncertain of the chemical constituent of this substance.
7. G. N. Dulnev, Personal communication (December, 1994).
8. G. S. Hubbard, P. P. Bentley, P. K. Pasturel & J. Isaacs, *A Remote Action Experiment with a Piezoelectric Transducer*, Final Report-Objective H, Task 3 and 3a, SRI International Project 1291 (Memo Park, CA, 1987).
9. V. A. Falkov & E. M. Keselman, A Study of a Trained Operator Effect on a Beam Balance, In *Sbornik rabot Assotsiatsii prikladnoy parapsikhologii* [Collection of papers of the Association for Applied Parapsychology] Leningrad Center for Information on Science and Technology Leningrad (in Russian, 1990), pp. 55-58.
10. A. B. Rubin, T. Ye. Krendeleva, S. I. Pogosyan & V. B. Turovetsky, Personal communication (November, 1993).
11. Yu. S. Dolin, V. A. Davydov, B. D. Lemeshko, I. V. Mirotin, E. V. Morozova & D. Ye. Shumov, Recording of Human Distant Influence on Plants, In *Sverkhslabye vzaimodeistviia v tekhnike, prirode i obshchestve* [Ultraweak interactions in technology, nature, and society], Abstracts of papers, [Moscow: A.S. Popov Scientific and Technological Society of Radio Engineering, Electronics, and Communications (in Russian, April, 1993)], pp. 19-20.
12. Ye. G. Pondarenko, Personal communication (December, 1993).
13. Yu. V. Tyagotin, & Ye. G. Bondarenko, A Study of Peculiarities of Growth of Hybrid Cells After They are Affected by "Biofield" of a Human Operator, In *Mezhregionalnaya nauchnaya konferentsiya: Problemy biopolya*, [Ippolit M. Kogan (Ed.), International Scientific Conference: Problems of the Biofield, Rostov-Yaroslavy: A.S. Popov Society, (in Russian) May, 1991], pp. 12-13.
14. E. V. Morozova, Yu. S. Dolin & D. Ye. Suponitsky, An Increase in the Frequency of Anomalies in Plants due to Human Distant Influence, In *Sverkhslabye vzaimodeistviia v tekhnike, prirode i obshchestve* [Ultraweak interactions in technology, nature, and society], Abstracts of papers, Moscow: A.S. Popov Scientific and Technological Society of Radio Engineering, Electronics, and Communications (in Russian, April, 1993), pp. 21-22.
15. N. V. Verzhilin, Personal communication (December, 1993).
16. S. V. Speransky, Personal communication (December, 1993).
17. A. Yu. Smirnov, Personal communication (December, 1993).
18. N. P. Yanova, Personal communication (December, 1993).
19. V. A. Otellin, Personal communication (December, 1993).
20. L. G. Dikaya & A. N. Gusev, Personal communication (December, 1993).
21. W. G. Braud & M. J. Schlitz, Consciousness Interactions with Remote Biological Systems: Anomalous Intentionality Effects, *Subtle Energies* 2, 1 (1991), pp. 1-46.

22. M. J. Schlitz & S. LaBerge, Autonomic Nervous System Detection of Remote Observation, *Proceedings of the 37th Annual Convention of the Parapsychological Association* (Amsterdam, Netherlands, August, 1994).
23. E. C. May, D. I. Radin, G. S. Hubbard, B. S. Humphrey & J. M. Utts, Psi Experiments with Random Number Generators: An Informational Model, In *Research in Parapsychology 1985* (D. H. Weiner & D. I. Radin, Eds, Scarecrow Press, Metuchen, NJ, 1986), pp. 119-120.
24. E. C. May, J. M. Utts & S. J. P. Spottiswoode, Decision Augmentation Theory: Toward a Model of Anomalous Mental Phenomena (Submitted for publication in the *Journal of Parapsychology*, in press).
25. C. T. Tart, Personal communication (April, 1994).